

was obtained. One-half of the filtrate from the silver chloride gave 0.0310 g. N, which, together with 12.7 cc. N measured over water at 20° and 760 mm., gives a total of 0.0765 g. N. The other half of the filtrate gave 0.1169 g. K₂SO₄.

The following results have been calculated from the above data:

	Calculated for AgNHK.NH ₃ .	Found.			
		I.	II.	III.	IV.
Ag.....	60.3	52.3	58.6	59.3	60.2
N.....	15.6	13.7	15.8	15.9	15.7
K.....	21.8	23.4	22.5	21.4	21.6
I.....	0.0	7.7	0.9	0.7	...

A compound of the composition represented by the formula AgNHK.NH₃ or AgNH₂.KNH₂ is therefore formed by the action of a solution of potassium amide on the amide of silver in accordance with a reaction represented by the equation



The salt separates from concentrated solutions in the form of beautiful crystals which are unaffected at a temperature of 100°. It is gradually discolored and decomposed by contact with the air. When heated over the open flame it decomposes vigorously but without explosive violence. In contact with water it decomposes but does not explode. This behavior is in marked contrast with that of silver amide which, it will be remembered, explodes with great violence on the slightest provocation, frequently without any assignable cause whatever. Liquid ammonia solutions of acids decompose potassium ammonoargentate, precipitating first silver amide which dissolves on further addition of the acid to form a silver salt of the acid used.

Summary.—It is shown in this paper that silver amide dissolves in a liquid ammonia solution of the ammono base, potassium amide, to form potassium ammonoargentate, an ammono salt of the composition represented by the formula AgNHK.NH₃ or AgNH₂.KNH₂.

STANFORD UNIVERSITY, CALIFORNIA.

[CONTRIBUTION FROM THE DEPARTMENT OF CHEMISTRY, UNIVERSITY OF CINCINNATI.]

INTERPRETATIONS OF SOME STEREOCHEMICAL PROBLEMS IN TERMS OF THE ELECTRONIC CONCEPTION OF POSITIVE AND NEGATIVE VALENCES.¹

PART III: A CONTINUATION OF THE INTERPRETATION OF THE BROWN
AND GIBSON RULE. PART IV: THE SIMULTANEOUS FORMATION
OF ORTHO-, META- AND PARA-SUBSTITUTED DERIVATIVES
OF BENZENE. PART V: A REPLY TO A. F. HOLLEMAN.

BY HARRY SHIPLEY FRY.
Received January 21, 1915.

Introduction.

In the first paper (I)² of this series, the electronic conception of positive

¹ Read before the Cincinnati Section, Am. Chem. Soc., Dec. 9, 1914.

² Fry, THIS JOURNAL, 36, 248 and 262 (1914).

and negative valences and the electronic formula for benzene were employed to interpret the anomalous behavior of many of the derivatives of benzene. In the second paper (II)¹ halogen substitution in the benzene nucleus and in the side-chain was considered from the same points of view. In each of these papers the theoretical deductions presented and applied were shown to be in accord with the experimental facts under consideration.

The present papers (III, IV, V) of the series are presented under one cover because they relate in general to the interpretation of the problems encountered in the simultaneous formation of ortho-, meta-, and para-disubstituted derivatives of benzene, and likewise to the simultaneous formation of the more complicated polysubstituted derivatives of benzene.

In Part III (A Continuation of the Interpretation of the Brown and Gibson Rule) a further analysis of this rule, based upon experimental facts, leads to deductions which are employed throughout the subsequent papers.

Part IV presents (1) an explanation of the simultaneous formation of ortho-, meta-, and para-substituted derivatives of benzene based upon the conception of *electronic isomerism* and the existence of *electromers in dynamic equilibrium, i. e., electronic tautomerism*. (2) A mechanism of these changes is described. (3) Holleman's proposed mechanism of, and hypotheses relating to, substitution are interpreted in terms of the electronic conception of positive and negative valences. (4) It is shown that there is a direct correlation of the author's electronic formula for benzene and rule for substitution with Holleman's hypotheses.

Part V presents a direct reply to each of the objections which Holleman has just recently published² against the author's electronic formula for benzene (abbreviated formula, Fig. 1) and general rule of substitution. This rule maintains that when substituents are of the same sign or polarity they occupy positions which are meta to each other, but if two substituents are of opposite sign or polarity they will occupy positions either ortho or para to each other. This follows from the fact that the electronic formula of benzene is the only formula which presents a structural basis and an electronic interpretation for the relations between the ortho and para positions and substituents in contradistinction to the meta positions and substituents.

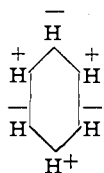

Fig. 1.

III. A CONTINUATION OF THE INTERPRETATION OF THE BROWN AND GIBSON RULE.³

(A) The Brown and Gibson Rule.⁴

The numerous instances in which certain monosubstituted derivatives

¹ THIS JOURNAL, 36, 1035 (1914).

² Holleman, *Ibid.*, 36, 2495 (1914).

³ See Fry, *Z. physik. Chem.*, 76, 385 and 398 (1911) for a detailed description of this rule and the derivation of the electronic formulas of benzene.

⁴ *J. Chem. Soc.*, 61, 366 (1892).

of benzene yield chiefly ortho and para disubstituted compounds, while other mono derivatives yield chiefly meta disubstituted products, have led to the formulation of the Brown and Gibson rule, the essential features of which must be briefly outlined. In the following abridged table,

A.	B.	C.	D.	E.
C_6H_5X	X	H.X	HO.X	...
C_6H_5Cl	Cl	H.Cl*	HO.Cl	<i>o-p</i>
$C_6H_5CH_3$	CH ₃	H.CH ₃ *	HO.CH ₃	<i>o-p</i>
$C_6H_5NH_2$	NH ₂	H.NH ₂ *	HO.NH ₂	<i>o-p</i>
C_6H_5OH	OH	H.OH*	HO.OH	<i>o-p</i>
$C_6H_5NO_2$	NO ₂	H.NO ₂	HO.NO ₂ *	<i>m</i>
C_6H_5COH	COH	H.COH	HO.COH*	<i>m</i>
C_6H_5COOH	COOH	H.COOH	HO.COOH*	<i>m</i>
$C_6H_5SO_2OH$	SO ₂ OH	H.SO ₂ OH	HO.SO ₂ OH*	<i>m</i>

Column A contains the formulas of a few monosubstituted derivatives; Column B, a few of the common substituents; Column C, the hydrogen compounds of these substituents; Column D, the hydroxyl compounds of the same substituents; Column E, the letters (*o-p*) or (*m*), according as the mono-derivatives give chiefly a mixture of ortho- and para-derivatives, or chiefly meta-derivatives. Brown and Gibson maintained that those substances marked with an asterisk in Column C "are not capable, by direct oxidation in one step, of being converted into the corresponding hydroxyl compound" in Column D. On the other hand, those substances asterisked in Column D can be formed by direct oxidation from the corresponding hydrogen compounds in Column C. Whenever the hydrogen compound is asterisked we find (*o-p*) in Column E. Whenever the hydroxyl compound is asterisked we find (*m*) in Column E. Brown and Gibson accordingly state their rule in these words: "...when X is naturally to be regarded as a derivative of HX, then C_6H_5X gives ortho- and para-derivatives; and when X is naturally to be regarded as a derivative of HOX, then C_6H_5X gives meta-derivatives." With very few exceptions (which are based upon the question of "direct oxidizability" of HX to HOX, to be considered later) the Brown and Gibson rule has been found to be capable of most rigorous application. Its authors did not look upon it as a law because there was "no visible relation to any mechanism by which substitution is carried out in one way rather than in another way."

It has been shown in detail in previous papers¹ that there is a very definite relation to a mechanism, which becomes evident when we determine the difference between X in HX and X in HOX. In the ordinary structural formulas no difference is apparent but from the electronic point of view, when H is positive and O is negatively divalent, it necessarily follows that X in HX functions negatively while X in HOX functions positively; as is evident in the electronic formulas $H \overset{+}{-} X$ and $H \overset{+}{-} O \overset{-}{-} X$.

¹ Fry, *Loc. cit.*

Accordingly, a mono-substituted derivative may be either $C_6H_5.X$ as a derivative of $H.X$, or $C_6H_5.X$ as a derivative of $HO.X$. Therefore, when X in $C_6H_5.X$ is negative and the entering substituent is positive, then ortho- and para-derivatives result. On the other hand, when X in $C_6H_5.X$ is positive and the entering substituent Y is positive, then meta-derivatives are formed. The following typical equations illustrate the above principles:

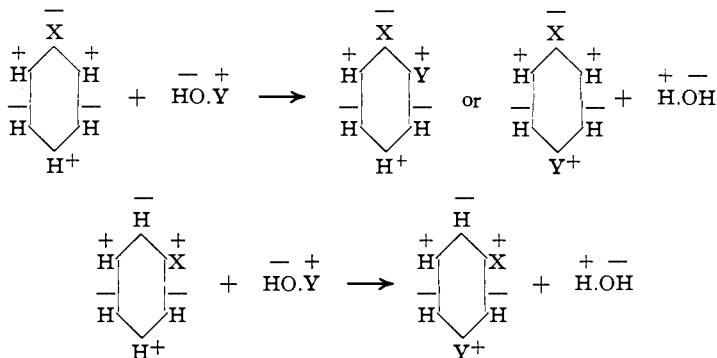

Thus, the electronic formula of benzene is correlated with the electronic interpretation of the Brown and Gibson rule, thereby showing a visible relation to a mechanism by which substitution is carried out in one way rather than in another way. In nuclear substitution it is assumed that the entering substituent is always positive as indicated in the above equations with the consequent elimination of $H.OH$ (or some other binary compound of the type $H.X$) conforming in general to the double decomposition type of reaction. Some substitution reactions involve oxidation and reduction as explained in a previous paper.¹ The entrance of Y as a positive substituent does not preclude its reverting to a negatively functioning substituent in accordance with the principle of "electronic tautomerism." These assumptions will be explained in detail and will be shown to accord with experimental facts.

(B) A Further Analysis of the Brown and Gibson Rule.

In presenting a further analysis of the Brown and Gibson rule it is necessary, first, to bring out the hidden significance of the difference between compounds of the type HX which are not directly oxidizable to HOX and those which are directly oxidizable to HOX .

Some writers have taken exception to this point of view which Brown

¹ The substitution of chlorine in the side chain is an oxidation and reduction phenomenon depending upon the reaction, $Cl^+ \longrightarrow Cl^- + 2\oplus$. Fry, THIS JOURNAL, 36, 1043 (1914).

and Gibson assumed as their basis of classifying substituents. For instance, Holleman¹ states that the rule,

"although remarkable and representing very well many of the observed facts, does not give satisfaction since it depends entirely upon the question of the direct oxidation of the hydrogen compounds of the substituents. Thus, at the time (1892) when Brown and Gibson published their rule, methane, $H.CH_3$, could not be oxidized directly to methyl alcohol, $HO.CH_3$; hence, according to the rule, the radical CH_3 should direct the entering substituent to the ortho and para positions. But since the time of the publication of the rule, Bone has proved that the primary oxidation product of methane during combustion is methyl alcohol. As a consequence, the radical CH_3 should then direct the entering substituent to the meta position. This discovery of Bone renders the rule inexact. While it is perfectly true that one can not directly transform $H.Cl$ to $HO.Cl$, yet on the other hand no one is certain that this will always be impossible."

Therefore, Holleman contends that with the progress of science the Brown and Gibson rule becomes less and less applicable.

Now this criticism of Holleman is only apparently justified, because Brown and Gibson unfortunately based their classification of substituents upon the debatable standpoint of the direct oxidizability in one step of HX to HOX . It has been shown that the chief point of distinction between the two classes of substituents is not the direct oxidizability of HX to HOX but rather depends upon the electronic interpretation of the rule in conjunction with the electronic formula of benzene, and the fact that X in HX is negative while X in HOX is positive. These points of view invalidate Holleman's criticism of the Brown and Gibson rule.

Further light may be thrown upon the nature of the substituents (X) commonly found in the benzene nucleus by considering the behavior of certain HOX compounds as oxidizing agents, and the susceptibility to oxidation of certain HX compounds, thus placing the Brown and Gibson classification on a different basis. Consider, first, a few of those substituents (OH , NH_2 , Cl and CH_3) which Brown and Gibson regarded as naturally derived from HX , not directly oxidizable to HOX . It is particularly noteworthy that the hydroxyl compounds of each of these substituents may function as an oxidizing agent while their hydrogen compounds are not oxidizing agents in the common sense of the word. Furthermore, the hydroxyl compounds of these substituents are less stable than their corresponding hydrogen compounds, *i. e.*, the entropy of the HX compound is less than the entropy of the HOX compound. When HOX functions as an oxidizing agent ($HOX \rightarrow HX + O$) yielding HX and oxygen (either free or combined) there is a change in the polarity of X from $\overset{+}{X}$ to $\overset{-}{X}$. This change may be represented as involving either an oxidation of negative hydroxyl ions by positive chlorine ions ($HO.Cl = HO +$

¹ Sur les regles de substitution dans le noyau benzique-Conference faite devant la Societe chimique de France, le 2 juin 1911. *Bull.*, 1911, 4e Serie 9. pp. 1-xlv.

$\overset{+}{\text{Cl}} \rightarrow \overset{+}{\text{H}} + \overset{-}{\text{Cl}} + \overset{-}{\text{O}}$ ¹ or an intramolecular oxidation and reduction
 $(\overset{+}{\text{H}}-\overset{-}{\text{O}}-\overset{-}{\text{X}} \rightarrow \overset{+}{\text{H}}-\overset{-}{\text{O}}-\overset{+}{\text{X}} \rightarrow \overset{+}{\text{H}}-\overset{-}{\text{X}} + \overset{-}{\text{O}})$ ². Now, since the
 compounds of the type HOX are less stable than those of the type HX,
 as shown by oxidation reactions, and since these oxidations involve the
 transition from $\overset{+}{\text{X}}$ to $\overset{-}{\text{X}}$, we may accordingly assume that $\overset{-}{\text{X}}$ is more stable
 than $\overset{+}{\text{X}}$.³ In other words, the tendency for X to function negatively is
 more pronounced than its tendency to function positively, but it may
 function either way as its $\overset{+}{\text{H}}\overset{-}{\text{X}}$ and $\overset{-}{\text{H}}\overset{+}{\text{O}}\overset{-}{\text{X}}$ compounds show. This may
 be postulated as a general property of those substituents which Brown
 and Gibson regarded as naturally derived from HX not directly oxidizable
 to HOX.

In order to complete the analysis of the Brown and Gibson rule it will
 be necessary to consider from the same points of view a few of those
 substituents, namely CO₂H, COH, SO₃H and NO₂, which were formerly
 regarded as belonging to the type HOX derivable by direct oxidation of
 HX. In fact, each of these HX compounds may be oxidized directly to
 the corresponding HOX compound, but it should be noted that X is a
 complex radical and the oxidation involves fundamental changes both
 in the number and polarity of the valences of certain atoms comprising
 these radicals. These features may be illustrated by the electronic equa-
 tions for the oxidations in which oxygen as O functions as the oxidizing
 agent through the acquisition of electrons and the consequent conver-
 sion of certain negative valences in the radical X to positive valences,⁴

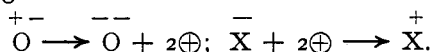

The complete electronic equations for the oxidations of (1) formic
 acid, (2) formaldehyde, (3) sulfurous acid, and (4) nitrous acid are as fol-
 lows: (1-4)

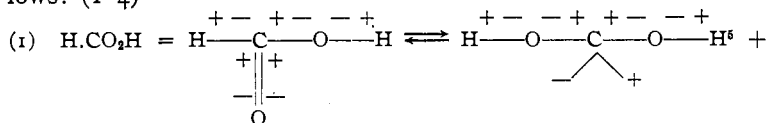

¹ For a more complete analysis of this change and the conditions under which it proceeds see Fry, THIS JOURNAL, 36, 267 (1914); *Ibid.*, 1044 (1914).

² Intramolecular oxidation and reduction has been described in detail by Jones, *Am. Chem. J.*, 50, 414 (1913); THIS JOURNAL, 36, 1268 (1914).

³ For the relation of this conception to the "nascent state" cf. Fry, THIS JOURNAL, 36, 272 (1914).

⁴ Oxidation and reduction reactions are presented from the positive and negative standpoint by Stieglitz, *Qual. Chem. Anal.*, Vol. I, Chaps. XIV and XV.

⁵ This change is comparable to keto-enol tautomerism. An electronic interpretation of same has been given by Fry, *Z. physik. Chem.*, 76, 405 (1911).

garded as naturally derived from HOX which results from the direct oxidation of HX.

Other points of significance may be noted in Equations 1-4 above. In formic acid, Equation 1, three of the carbon valences are positive while the fourth is negative. In carbonic acid, four carbon valences are positive. Prior to the action of $\overset{+-}{O}$, formic acid is in equilibrium with a tautomeric modification in which the carbon atom is bivalent and shows one free positive and one free negative valence. These free valences unite with $\overset{+-}{O}$ and, either simultaneously or subsequently, the negative carbon valence is oxidized to a positive valence and oxygen ($\overset{+-}{O}$) thereby becomes negatively divalent ($\overset{+-}{O}$). The tautomeric modification of formic acid, showing a free positive and a free negative valence, would through the polarization of these valences present an illustration of a bivalent carbon compound.¹ Another illustration is shown in Equation 2.

Furthermore it should be noted in Equation 3 that sulfurous acid ($H.SO_3H$) is ordinarily written ($HO.SO_2H$), in which the sulfur atom (comparable to the carbon atom above shows a free positive and a free negative valence, and the polarization of these valences renders sulfur tetravalent; but, on oxidation to sulfuric acid, the sulfur atom becomes hexavalent. In precisely the same manner nitrous acid ($H.NO_2$) is commonly written ($HO.NO$) in which nitrogen is trivalent; but oxidation to nitric acid renders nitrogen pentavalent. Now Equations 1-4 show that formaldehyde, formic acid, sulfurous acid and nitrous acid belong to the same class and same type of oxidizable compounds. Since the sulfur atom in sulfurous acid increases its valence by two on oxidation to sulfuric acid, and since the nitrogen atom in nitrous acid likewise increases its valence by two when oxidized to nitric acid, it follows, similarly, that the carbon atom in formaldehyde and in formic acid must undergo likewise an increase of two in its valence when the compounds are oxidized to formic acid and carbonic acid, respectively. In other words, this classification of the substituents and the electronic system of oxidation lends further support to and an electronic interpretation of the existence of bivalent carbon compounds.

Summary of Part III.

The extended interpretation and analysis of the Brown and Gibson rule brings out the following facts:

¹ Stieglitz (*Loc. cit.*, Vol. I, pp. 269-298) has given a detailed account of the oxidation of carbon compounds, in particular formaldehyde, showing by means of the chemometer that there is involved an actual transfer of electrical charges. The classification of sulfurous and nitrous acids with formaldehyde in the present discussion leads to the suggestion that certain sulfites and nitrites might lend themselves to similar significant demonstrations. See also Stieglitz, *Science*, 27, 774 (1908).

1. Certain substituents (OH, Cl, Br, I, NH₂, CH₃, etc.) lead to the formation chiefly of ortho and para derivatives of benzene, because their tendency to function negatively is more pronounced than their tendency to function positively. This tendency may be formulated thus: $\overset{-}{X} > \overset{+}{X}$.

2. Certain other substituents (CO₂H, COH, SO₃H, NO₂, etc.) lead to the formation chiefly of meta derivatives of benzene, because their tendency to function positively is more pronounced than their tendency to function negatively. This tendency may be formulated thus: $\overset{+}{X} > \overset{-}{X}$.

3. The objections which have been directed against the Brown and Gibson rule have been based upon the question of the direct oxidizability of HX to HOX. These objections are invalid, because the distinction between the two classes of substituents rests upon the facts summarized in paragraphs (1) and (2) above, and the fact that X in HX is negative while X in HOX is positive. These distinctions, in conjunction with the electronic formula of benzene, show why certain monosubstituted derivatives of benzene yield chiefly ortho- and para-disubstituted derivatives, while others yield chiefly meta-disubstituted derivatives.

IV. THE SIMULTANEOUS FORMATION OF ORTHO-, META- AND PARASUBSTITUTED DERIVATIVES OF BENZENE.

Previous papers¹ relating to substitution in the benzene nucleus from the electronic point of view have interpreted the formation of ortho and para compounds on the one hand, and meta-compounds on the other, as distinct and separate processes because, as a general rule, a given monosubstituted compound yields chiefly a meta-derivative or a mixture of ortho- and para-derivatives. But in many reactions there results a mixture of ortho-, meta-, and para-disubstituted derivatives in which the quantities of the isomers vary. Consequently it becomes necessary to explain (A) the simultaneous formation of ortho-, meta- and para-disubstituted derivatives; and also (B), the simultaneous formation of polysubstituted derivatives. These explanations involve the electronic formula of benzene, the rule of substitution, and the conception of electronic isomers or electromers in dynamic equilibrium, i. e., electronic tautomerism.

The substituents (X) commonly found in the benzene nucleus were shown in Part III to function either positively or negatively according as they were derivatives of the types $\overset{-}{HO}\overset{+}{X}$ or $\overset{+}{H}\overset{-}{X}$, respectively. Now it has also been shown in a previous paper² that a number of these substituents may function either negatively or positively when in combination with carbon atoms of the benzene nucleus. For instance, chlorine is

¹ Fry, *Loc. cit.*, THIS JOURNAL, and *Z physik. Chem.*

² Fry, THIS JOURNAL, 36, 265 (1914).

negative in *o*- and *p*-chloronitrobenzenes, but positive in *m*-chloronitrobenzene and in 2,4,6-trichloroacyl nitrogen chloride. A particularly noteworthy example is afforded by the (SO₃H) radical, which in phenylsulfonic acid functions either negatively or positively, depending upon certain conditions. For instance, phenylsulfonic acid on hydrolysis (1) in alkaline solution yields phenol and sulfurous acid while (2) in acid solution the products of hydrolysis are benzene and sulfuric acid. Hence, the following equations:

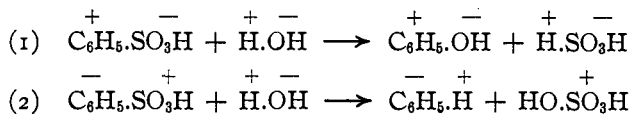

In connection with the facts that certain substituents in the benzene nucleus may function either positively or negatively, consider the following quotation from a previous paper:¹

"The hypothesis of positive and negative valences suggests the possibility of there being at least two distinct types or electromers of a binary compound. Hence two mono substituted derivatives of benzene, $\overset{+}{\text{C}_6\text{H}_5}\overset{-}{\text{X}}$ and $\overset{-}{\text{C}_6\text{H}_5}\overset{+}{\text{X}}$, should be possible while only one is known. Therefore, if both electromers exist and only one substance is identified, it follows that the electromers are either not distinguishable by (present) physical methods, or that one electromer is transformable into the other through the transposition of electrons: $\overset{+}{\text{C}_6\text{H}_5}\overset{-}{\text{X}} \rightleftharpoons \overset{+}{\text{C}_6\text{H}_5}\text{X} \rightleftharpoons \overset{-}{\text{C}_6\text{H}_5}\overset{+}{\text{X}}$."

This quotation presented the first definition of the conception of "electronic tautomerism," that is, the existence of electromers in dynamic equilibrium.²

At the present time *tautomerism* is applied to that state of substances in which only the equilibrium mixture of the structural isomers is known. Correspondingly, the term *electronic tautomerism* is applied herewith to substances in which only the equilibrium mixture of the *electronic isomers* or *electromers* is known. From this point of view phenylsulfonic acid may be regarded as an equilibrium mixture of the electromers $\overset{+}{\text{C}_6\text{H}_5}\overset{-}{\text{X}}$ and $\overset{-}{\text{C}_6\text{H}_5}\overset{+}{\text{X}}$, and any other mono- or polysubstituted derivative of benzene may be regarded similarly, as will be shown later.

(A) The Simultaneous Formation of Ortho-, Meta- and Para-Disubstituted Derivatives of Benzene.

Electronic tautomerism of monosubstituted derivatives of benzene will

¹ Fry, *Z. physik. Chem.*, **76**, 390 (1911).

² The conception of electronic tautomerism has been applied in many significant ways. See articles by L. W. Jones (*Am. Chem. J.*, **50**, 414 (1913)); THIS JOURNAL, **36**, 1268 (1914); Stieglitz, *Loc. cit.*, THIS JOURNAL, **36**, 272 (1914); Bray and Branch, THIS JOURNAL, **35**, 1440 (1913); see also article on the existence of electromers of nitrogen chloride by W. A. Noyes, *Ibid.*, **35**, 767 (1913).

now be employed to explain the simultaneous formation of ortho-, meta-, and para-disubstituted derivatives of benzene. Consider any mono-substituted derivative of the general formula C_6H_5X which is now regarded as $(C_6H_5.X \rightleftharpoons C_6H_5.X)$. Indicating the polarities of the hydrogen atoms of the nucleus the equilibrium is represented thus:

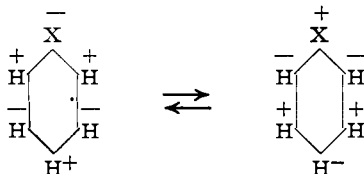

Note particularly that the change in the polarity of the substituent X involves simultaneously a change in the polarities of the hydrogen atoms, but that in each electromer those atoms (or substituents) ortho and para to X are opposite in sign to X, while those atoms (or substituents) meta to X are of the same sign as X. This, of course, is the essential feature of all of the electronic formulas of benzene, namely that hydrogen atoms or substituents in positions 1, 3, and 5 of any given electromer are opposite in sign to the hydrogen atoms or substituents in positions 2, 4 and 6 of the same electromer, otherwise the symmetry, and consequently the stability, of the benzene nucleus could not be maintained. A detailed mechanism of the transpositions of electrons, the centric valences, etc., involved in the electronic tautomerism of benzene derivatives will be given later in this paper. For the present, the simpler formulas involving only the hydrogen atoms and substituents are sufficient.

It is a well established fact that in a mixture of two isomers ($A \rightleftharpoons B$), capable of changing one into the other with such readiness that the balance between them is rapidly restored, the addition of a given substance C will result in reaction either with A, or with B, or with both A and B. If interaction occurs between A and C, B will be transformed into A on account of the disturbance of the equilibrium. The mixture then reacts as though it consisted wholly of A. If C reacts only with B, the mixture behaves, for the same reason, as though B were the only substance present. In some instances two simultaneous independent reactions may occur, namely, the interaction of A and C simultaneously with the interaction of B and C. In a precisely similar manner a given reagent, $HO.Y$, in the presence of a tautomeric mixture of electromers ($C_6H_5.X \rightleftharpoons C_6H_5.X$) may react with the one electromer or the other, or with both electromers. A complete scheme of interaction is shown in the following electronic equations:

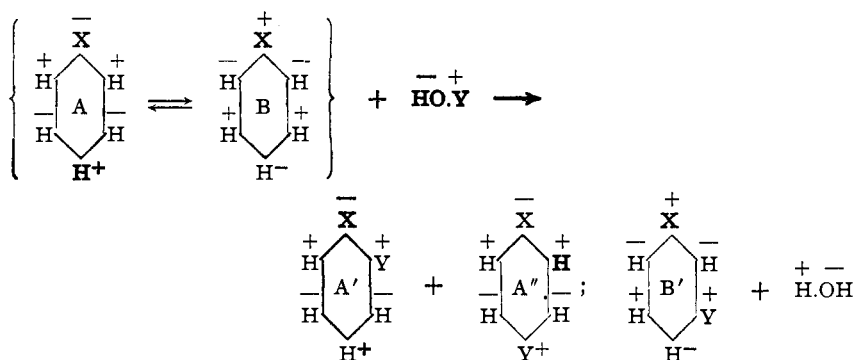

It should be observed that if $\text{HO}\cdot\text{Y}$ reacts only with $\text{C}_6\text{H}_5\cdot\text{X}$ (electromer A), then only ortho- and para-disubstituted derivatives (A' and A'') are formed. If $\text{HO}\cdot\text{Y}$ reacts only with $\text{C}_6\text{H}_5\cdot\text{X}$ (electromer B), then only a meta-disubstituted derivative (B') results. If $\text{HO}\cdot\text{Y}$ interacts simultaneously with both electromers (A and B) then ortho-, meta-, and para-disubstituted derivatives (A' , B' and A'' , respectively) will be formed. The possibility and the extent of these reactions (as in all reactions with tautomeric substances) are dependent upon several conditions such as the solvent medium, catalytic agent, temperature, concentrations of the electromers, the speed of transition of one electromer into the other, and the respective speeds of interaction of the substituting agent with the respective electromers. These conditions are the problems which confront us in all research involving tautomers and likewise will be met in the case of electronic tautomers.

Having given a general scheme for the simultaneous formation of ortho-, meta- and para-disubstituted derivatives, one of the many examples which are in accord with and, therefore, confirm the scheme should now be considered. For instance, in the nitration of toluene, the substituent (X) already present in the nucleus is the methyl radical, which may function either positively or negatively; but in Part III it has been shown that its tendency to function negatively is more pronounced than its tendency to function positively, *i. e.*, $\overset{-}{\text{CH}_3} > \overset{+}{\text{CH}_3}$. Hence, in the tautomeric equilibrium, $\overset{+}{\text{C}_6\text{H}_5}\cdot\overset{-}{\text{CH}_3} \rightleftharpoons \overset{-}{\text{C}_6\text{H}_5}\cdot\overset{+}{\text{CH}_3}$, the former electromer would predominate and interaction with $\text{HO}\cdot\text{NO}_2$ would lead to a greater yield of *o*- and *p*-nitrotoluenes than of *m*-nitrotoluene. The predominance or preponderance of the electromer $\overset{-}{\text{C}_6\text{H}_5}\cdot\overset{+}{\text{CH}_3}$ over the electronic tautomer $\overset{+}{\text{C}_6\text{H}_5}\cdot\overset{-}{\text{CH}_3}$ may be correlated with the speeds of re-

action with nitric acid, *i. e.*, if the former electromer reacts more rapidly than does the latter electromer, then the yield of *o*- and *p*-nitrotoluenes would exceed that of *m*-nitrotoluene.¹ These assumptions are confirmed by experimental facts, since toluene when nitrated yields 56.00% of the *o*-, 40.90% of the *p*-, and 3.10% of the *m*-nitrotoluene. The simultaneous formation of the three isomers is indicated in the following scheme:

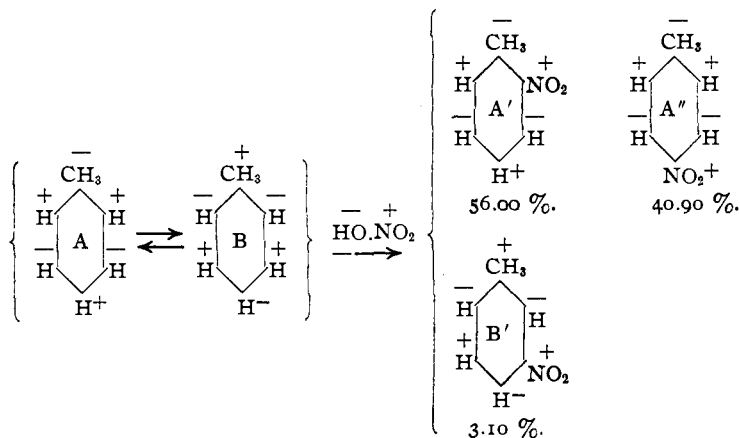

Consider now, on the other hand, the nitration of benzoic acid. The substituent (X) already present in the nucleus is CO₂H, which may function either positively or negatively, but CO₂H⁺ > CO₂H⁻, *i. e.*, the tendency for the carboxyl radical to function positively is more pronounced than is its tendency to function negatively.² Accordingly in the equilibrium, C₆H₅.CO₂H⁺ ⇌ C₆H₅.CO₂H⁻, the latter electromer (in which the carboxyl radical is positive) would predominate, and if its speed of interaction with HO.NO₂⁺ is greater than the speed of interaction between C₆H₅.CO₂H⁺ and HO.NO₂⁻ then the yield of *m*-nitrobenzoic acid should exceed that of the ortho and para compounds. These assumptions are confirmed by the facts, since benzoic acid on nitration yields 80.30% of the meta compound, 18.50% of the ortho, and 1.20% of the *p*-nitrobenzoic acid. The electronic equations conform to the general scheme given above.

Many other examples³ of the simultaneous formation of ortho-, meta-,

¹ The predominance of one electromer over the other may be regarded as equivalent to a greater concentration of the one electromer. Since concentration is a principle factor of the velocity of reaction, it is evident that a direct relationship exists between the predominance or preponderance of a given electromer and the velocity of the substitution reaction in which it is engaged.

² Other relationships between the properties of the carboxyl radical and its polarity are given by Fry, *THIS JOURNAL*, 36, 254-262 (1914).

³ Holleman, *Loc. cit.*, tabulations on p. 23.

and para-disubstituted derivatives of benzene might be presented in detail. They are in complete agreement with, and accordingly confirm, the principle of the electronic tautomerism of the electromers of the benzene derivatives, the general rule for substitution, and the scheme for the simultaneous formation of ortho-, meta-, and para-disubstituted derivatives of benzene.

(B) **The Simultaneous Formation of Polysubstituted Derivatives of Benzene.**

The principles underlying the simultaneous formation of polysubstituted derivatives of benzene are identical with those just given in the preceding section (A), and may be illustrated by considering the introduction of a third substituent (Z) into (1) an ortho-, (2) a para-, and (3) a meta-disubstituted derivative, C_6H_4XY .

Scheme (1).—**Introduction of a Third Substituent Into an Ortho-Disubstituted Derivative.**

Here the electronic tautomerism involves two electromers of an ortho-derivative. These electromers will be designated by the letters A and B while their substitution products will be indicated by A' , A'' , etc., and B' , B'' , etc., respectively. The general scheme (1) for the introduction of the third substituent Z is as follows.

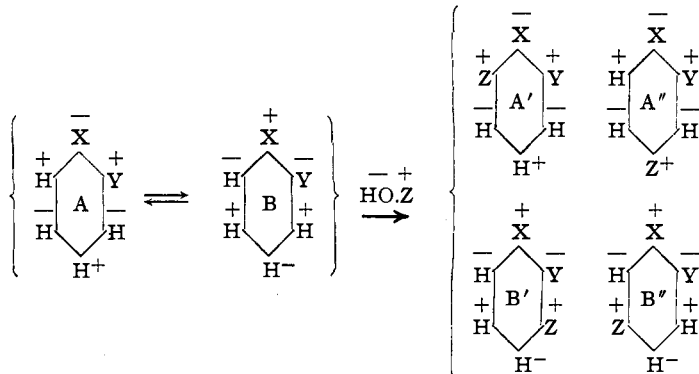

Theoretically and electronically four trisubstituted isomers are obtainable, namely, A' and A'' from electromer A, and B' and B'' from electromer B. A remarkable experimental confirmation of this scheme is found in the work of Wibaut¹ who showed that the nitration at 0° of *o*-chlorotoluene yielded all four possible mononitro compounds in considerable quantity. The electronic interpretation is embodied in the following equations, which are perfectly comparable to the equations of scheme (1) above. The percentage yield of each isomer will be indicated beneath the appropriate electronic formula.

¹ Wibaut, *Recueil*, 32, 244 (1913).

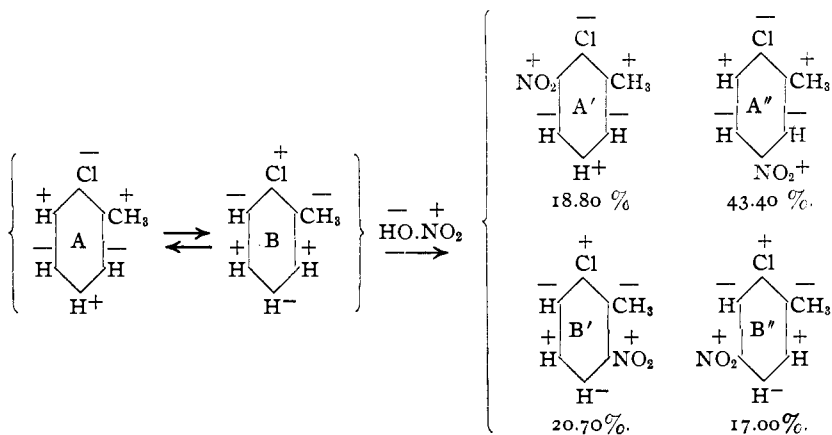

In section (B) of Part III it was shown that $\text{Cl} > \text{Cl}$, and $\text{CH}_3 > \text{CH}_3$, *i. e.*, the chlorine and methyl radicals tend to function negatively rather than positively, but in *o*-chlorotoluene (either electromer, A or B) the substituents must be opposite in polarity. This leads to the consideration of a significant question, namely, will the polarities of the substituents present in the nucleus predetermine in any way the relative quantities of the isomeric derivatives which are formed? In the simultaneous formation of the isomeric disubstituted derivatives of benzene the polarities of the substituents and the tendencies of certain substituents to function in one way rather than in another way were shown to be related to the relative quantities of the isomers (ortho and para on the one hand, and meta on the other) which were formed. Now in the case of *o*-chlorotoluene the two substituents present naturally tend to function negatively, but since one must function negatively while the other functions positively another question arises, namely, is the tendency for chlorine to function negatively more pronounced than the tendency for methyl to function negatively? The answer to this important question can be derived in an indirect way by comparing the general stability of methyl alcohol ($\text{HO} \cdot \text{CH}_3$) with that of hypochlorous acid ($\text{HO} \cdot \text{Cl}$). The latter is undoubtedly the less stable, since it is readily decomposed by light or heat, whereas methyl alcohol is a comparatively stable compound. Now, the instability and decomposition of hypochlorous acid involves the change, as previously shown, from Cl to Cl , and since $\text{HO} \cdot \text{Cl}$ is less stable than $\text{HO} \cdot \text{CH}_3$, naturally it may be assumed that the tendency for chlorine to function negatively is more pronounced than the tendency for methyl to function negatively, *i. e.*, $\text{Cl} > \text{CH}_3$. Or in equivalent terms, the tendency for methyl to function positively is more pronounced than the tendency

for chlorine to function positively,¹ *i. e.*, $\overset{+}{\text{CH}_3} > \overset{-}{\text{Cl}}$, since $\overset{-}{\text{HO}}.\overset{+}{\text{CH}_3}$ is more stable than $\overset{-}{\text{HO}}.\text{Cl}$.

These relationships lead to the conclusion that of the two electromers (A and B) of *o*-chlorotoluene, the one (A), in which (Cl) is negative and (CH₃) is positive, would predominate, which in turn would indicate that the nitration of *o*-chlorotoluene might yield a greater quantity of the nitrochlorotoluenes A' and A'', than of the nitrochlorotoluenes B' and B''. These assumptions are confirmed by the facts, since Wibaut (*loc. cit.*) has determined the yields of the four mononitro-*o*-chlorotoluenes to which are assigned, herewith the abbreviated electronic formulas in conformity with the preceding scheme of substitution:

Electromer (A) →	$(A'), \overset{+}{\text{C}_6\text{H}_4}.\overset{-}{\text{CH}_2}.\overset{+}{\text{Cl}}.\overset{+}{\text{NO}_2}$ (1,2,3).....	18.8%
Electromer (A) →	$(A''), \overset{+}{\text{C}_6\text{H}_4}.\overset{-}{\text{CH}_3}.\overset{+}{\text{Cl}}.\overset{+}{\text{NO}_2}$ (1,2,5).....	43.4%
		62.2%
Electromer (B) →	$(B'), \overset{-}{\text{C}_6\text{H}_4}.\overset{+}{\text{CH}_3}.\overset{-}{\text{Cl}}.\overset{+}{\text{NO}_2}$ (1,2,6).....	20.7%
Electromer (B) →	$(B''), \overset{-}{\text{C}_6\text{H}_4}.\overset{+}{\text{CH}_3}.\overset{-}{\text{Cl}}.\overset{+}{\text{NO}_2}$ (1,2,4).....	17.0%
		37.7%

The combined yields of A' and A'' total 62.2% as against 37.7%, the combined yields of B' and B''.

Scheme (2).—Introduction of a Third Substituent Into a Para-Disubstituted Derivative.

Consider now the introduction of a third substituent into a para-disubstituted derivative of benzene according to the following scheme (2):

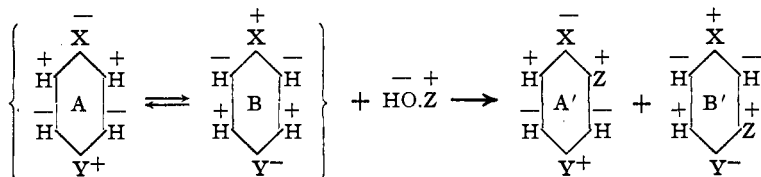

Theoretically and electronically two and only two trisubstituted derivatives are possible, namely, A' and B' from electromers A and B, respectively. One of several series of experiments which confirm the above scheme is the nitration at *o*° of *p*-chlorotoluene by Holleman,² who demonstrated that only two mononitro-*p*-chlorotoluenes were produced. The

¹ The tendency for a radical to function in one way rather than in another way may be defined as its "polar stability." Other methods of determining the polar stability of a given radical will be described in a subsequent paper of this series.

² Holleman, *Recueil*, **28**, 408 (1909).

correlation of these facts with the electronic formulas is embodied in the following scheme:

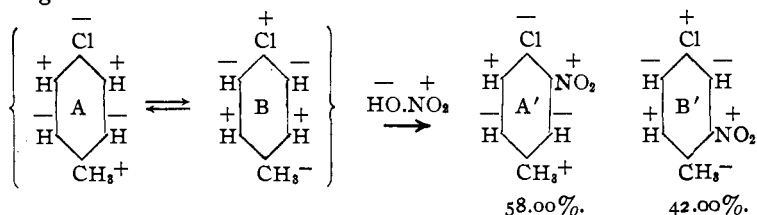

Since, as previously indicated, $\overset{-}{\text{Cl}} > \overset{+}{\text{CH}_3}$ and $\overset{+}{\text{CH}_3} > \overset{-}{\text{Cl}}$, electromer A would predominate and, accordingly, the nitration of *p*-chlorotoluene would be expected to yield a greater quantity of A', $\overset{+}{\text{C}_6\text{H}_3}\cdot\overset{-}{\text{CH}_3}\cdot\overset{+}{\text{Cl}}\cdot\overset{-}{\text{NO}_2}$ (1, 4, 3), than of B', $\overset{-}{\text{C}_6\text{H}_3}\cdot\overset{+}{\text{CH}_3}\cdot\overset{-}{\text{Cl}}\cdot\overset{+}{\text{NO}_2}$ (1, 4, 2). This assumption also is confirmed by the actual yields, namely, 58.00% of A' and 42.00% of B'.

Scheme (3).—Introduction of a Third Substituent Into a Meta-Disubstituted Derivative.

The introduction of a third substituent into a meta-disubstituted derivative of benzene corresponds to the following general scheme (3):

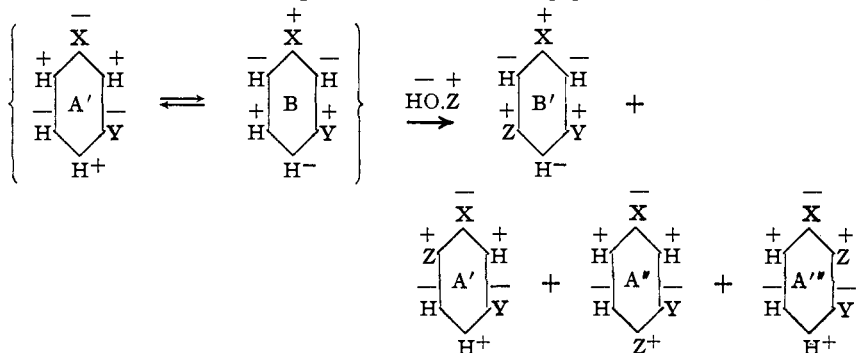

Since the substituents X and Y occupy positions meta to each other they must be of the same polarity, *i. e.*, both are negative in A while both are positive in B. Some interesting theoretical and experimental results present themselves depending upon the tendencies of X and Y to function positively or negatively. If both X and Y belong to that class of substituents which lead to the formation chiefly of ortho and para derivatives (which is the case when $\overset{-}{\text{X}} > \overset{+}{\text{X}}$ and $\overset{-}{\text{Y}} > \overset{+}{\text{Y}}$), then electromer A would predominate and the chief substitution products would be A', A'', and A'''. Furthermore, since X and Y are meta to each other and each is naturally negative, electromer A might predominate to the exclusion of electromer B; and the introduction of a third substituent Z

would lead to the formation of only three isomeric trisubstitution products, namely, A', A'', and A'''. Just such a case is found in the nitration at 0° of *m*-chlorotoluene by Wibaut (*loc. cit.*). The percentage yields of the isomers are indicated in the scheme:

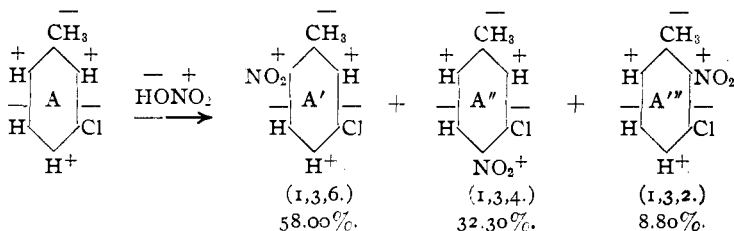

Now it has been shown that the tendency for chlorine to function negatively is more pronounced than the tendency for methyl to function negatively, *i. e.*, $\text{Cl} > \text{CH}_3$. This leads to the assumption that the entering positive nitro radical would be more subject to the directing influence of Cl than of CH_3 . Now Cl directs NO_2 to the para position rather than to the ortho position, since chlorobenzene on nitration yields 69.90% of *p*-nitrochlorobenzene and 30.10% of *o*-nitrochlorobenzene. On the other hand, CH_3 directs NO_2 to the ortho position rather than to the para positions since toluene on nitration yields 56.00% of the *o*- and 40.90% of the *p*-nitrotoluene. Accordingly, when *o*-chlorotoluene is nitrated, one should expect the greatest yield to be that of isomer (A') in which NO_2 occupies a position para to Cl and ortho to CH_3 . A smaller yield would be predicted for that isomer (A'') in which NO_2 is ortho to Cl and para to CH_3 . The smallest yield would be predicted for the isomer (A''') in which NO_2 is ortho to Cl and ortho to CH_3 . These assumptions are fully confirmed by the facts since the respective yields of the three isomers, A', A'', and A''', are, respectively, 58.00%, 32.00%, and 8.80%.¹

Returning again to the general scheme (3) above, it should be noted that if X and Y belong to that class of substituents which lead to the formation chiefly of meta derivatives, which is the case when $\text{X} > \text{X}$ and $\text{Y} > \text{Y}$, then electromer B would predominate. Accordingly, the introduction of a third substituent Z would lead to the formation chiefly of the trisubstitution product in which all three substituents (X, Y and Z) are positive. Many examples are found in the literature which show that

¹ This constitutes a further proof that the polarities of the substituents in the nucleus and their tendencies to function in one way rather than in another way predetermine not only the type of substitution but also the relative quantities of the isomers produced.

when the substituents in the nucleus are positive, the entering substituent assumes a position meta to those present, and the predominating isomer corresponds to B', the derivative of electromer B. Exact quantitative data upon the amounts of the other possible isomers have not been found in the literature.

Having considered all of the possibilities which might be encountered in the introduction of a third substituent Z into an ortho-, a para-, and a meta-disubstituted derivative, C_6H_4XY , of benzene, and having shown that experimental facts and data are in agreement with the theoretical deductions, with the electronic formulas, and the principle of electronic tautomerism, and with the general electronic rule for substitution, it should be added that the formation of other poly-substituted derivatives of benzene will conform in general to the principles and rule previously developed and illustrated. This claim is warranted by a careful study of the numerous tables of the variously substituted derivatives of benzene which have been compiled with great care and presented by Holleman in his extended work¹ on the influence of the substituents in the benzene nucleus, and the principles of substitution.²

(C) The Mechanism of Electronic Tautomerism of Benzene Derivatives.

The important part played by the principle of electronic tautomerism in the explanation of substitution in the benzene nucleus leads to the consideration of a mechanism which involves the centric valences of the carbon atoms of the nucleus. The key to this mechanism is embodied in the assumption (to be substantiated by experimental facts) that when a given hydrogen atom or substituent is negative it is united to a carbon atom which possesses a positive centric valence. On the other hand, when a hydrogen atom or substituent is positive it is united to a carbon atom which possesses a negative centric valence. These assumptions are embodied in the following formulas illustrating more completely

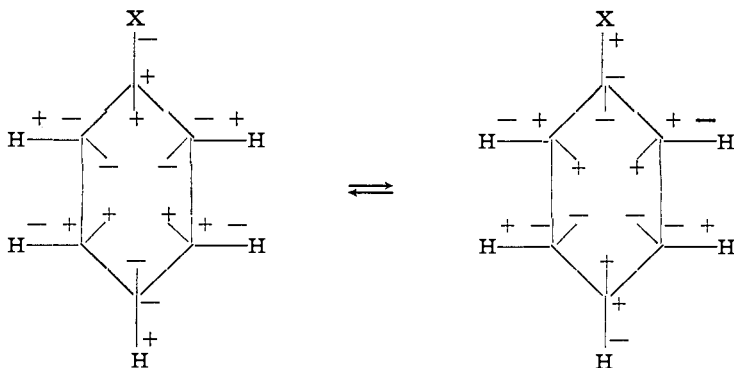

¹ Die direkte Einführung von Substituenten in den Benzolkern.

² Sur les règles de substitution dans le noyau benzique (*Loc. cit.*).

the electronic tautomerism of a monosubstituted derivative. The electronic tautomerism of a polysubstituted derivative would conform to the same principles and scheme.

When \bar{X} becomes $\overset{+}{X}$ ($\bar{X} \rightarrow \overset{+}{X} + 2\ominus$) the polarity of the carbon valence binding X is changed from positive to negative, *i. e.*, in terms of the electronic conception of oxidation and reduction, the positive valence has been reduced to a negative valence. On the other hand, when $\overset{+}{X}$ becomes \bar{X} , the valence binding X is changed from negative to positive, *i. e.*, it is oxidized. Simultaneously, corresponding changes occur in the polarities of each of the other hydrogen atoms or substituents and the carbon valences binding same. In other words, for each oxidation there is a corresponding reduction; otherwise, the symmetry and consequently the stability of the benzene nucleus would be destroyed.¹

Another important point to be observed in the above scheme is that the transition from the one electromer to the other involves a change in the polarity of each centric valence. This type of change has been defined as "centric rearrangement." A complete scheme of the several possible centric formulas of benzene and their transitions to the Kekulé formulas has been shown to involve changes from double bonds of the type $(\overset{+}{C}=\overset{-}{C})$, defined as "contraplex," to double bonds of the type $(\overset{-}{C}=\overset{+}{C})$, defined as "diplex." Such changes, "contraplex-diplex transitions," take place in those compounds which show distinct bands in their absorption spectra.² Accordingly, they serve as a structural basis for the relationship between chemical constitution and absorption spectra. In other words, the rearrangements of the centric valences and the concomitant contraplex-diplex transitions cause a disturbance in the vibrations of the systems of electrons, whereby light of correlated period is absorbed in accordance with the theory of resonance. By means of the various electronic formulas of benzene and their systems of dynamic equilibria, I have been able to demonstrate that a definite relationship exists between the oscillation frequencies of the seven bands in the absorption spectrum of benzene and the numbers of contraplex-diplex transitions involved, which function as the origin of the respective absorption bands. This relationship is that of a linear function expressed by the equation, $y = 21.60628x + 3679.509$, in which (y) is the oscilla-

¹ An explanation of the stability of the benzene nucleus based upon the fact that the number of positive hydrogen atoms of the nucleus must be equal to the number of negative hydrogen atoms, is given by Fry, *THIS JOURNAL*, 36, 270 (1914).

² The definitions and principles indicated in this paragraph are fully described in a paper on the absorption spectra of benzene, Fry, *Z. physik. Chem.*, 76, 398 (1911).

tion frequency of a given band, and (x) is the number of contraplex-diplex transitions functioning as the origin of the given band. The deviations of the calculated frequencies from the observed frequencies were less than the limits of error in experimental observation. Other similar and exact relationships were developed and found to hold for the oscillation frequencies of the absorption bands of naphthalene,¹ chlorobenzene and bromobenzene,² and for the fluorescence bands of anthracene and phenanthrene.³ This work has been briefly indicated here because through these physical measurements an experimental confirmation is offered for the hypothesis of contraplex-diplex transitions which involve centric rearrangements, *i. e.*, changes in the polarities of the centric valences of benzene. These centric valences and rearrangements will now be shown to play a very definite part in the further development of the mechanism of substitution on the benzene nucleus.

(D) The Mechanism of Substitution in the Benzene Nucleus and an Electronic Interpretation of the Hypothesis of Holleman.

Holleman in his work on "Die direkte Einführung von Substituenten in den Benzolkern" has described and discussed the various hypotheses which have been advanced at different times to explain the rules of substitution, but he is of the opinion that none of these hypotheses are able to give a satisfactory explanation of the facts. Furthermore, Holleman, in a very recent paper⁴ makes this statement:

"Notwithstanding the fact that the problem of substitution in the benzene nucleus has been studied intensively enough of late, there still remains a fundamental question which has not yet been solved; it is the question of knowing the reason why such or such group directs a new substituent chiefly to the para-ortho positions or chiefly to the meta position."

A propos of this statement, it has been shown in Part III, Section B, of this series of papers (and in previous papers) that the electronic formula of benzene and the electronic interpretation of the Brown and Gibson rule afford an explanation, in the sense that if the substituent in the nucleus is negative then the entering positive substituent must assume a position either ortho or para to the substituent already present; and, if the substituent in the nucleus is positive, then the entering positive substituent must assume a position meta to the one already present. This hypothesis has been substantiated by numerous examples of substitution. The mechanism, or schemes, for these reactions as previously presented involved the simplified electronic formulas for benzene indicating only the polarities of the hydrogen atoms and substituents,

¹ Fry, *Z. physik. Chem.*, **76**, 591 (1911).

² Fry, *Ibid.*, **82**, 665 (1913).

³ Fry, *Ibid.*, **80**, 29 (1912).

⁴ *Recueil*, **33**, 1 (1914).

and the electronic formulas of the substituting reagents; but, since it is generally conceded that substitution in the nucleus involves (1) the addition of the substituting reagent (for example, $\overset{-}{\text{O}}\overset{+}{\text{Y}}$) and (2) the elimination of certain elements (for example, $\overset{+}{\text{H}}\overset{-}{\text{O}}\text{H}$), it follows that any mechanism proposed to account for these changes (1 and 2) must consider the part played by the centric valences or the double bonds of the nucleus. For the present, it is simpler to indicate the part played by the free centric valences in effecting the addition of the substituting reagent, rather than to picture the part as played by the "opening up" or "breaking" of the double bonds. In either case, the mechanism of the change involved would amount to one and the same thing, since the centric formula is simply an intermediate phase between those Kekulé formulas or phases which possess double bonds.

From the above points of view a more complete mechanism of substitution will be indicated; first, for the formation of an ortho-disubstituted derivative, in which case the substituent (X) present in the nucleus functions negatively and the entering substituent (Y) is positive. The formulas will indicate only the polarities of the bonds or valences which are immediately related to the particular changes.

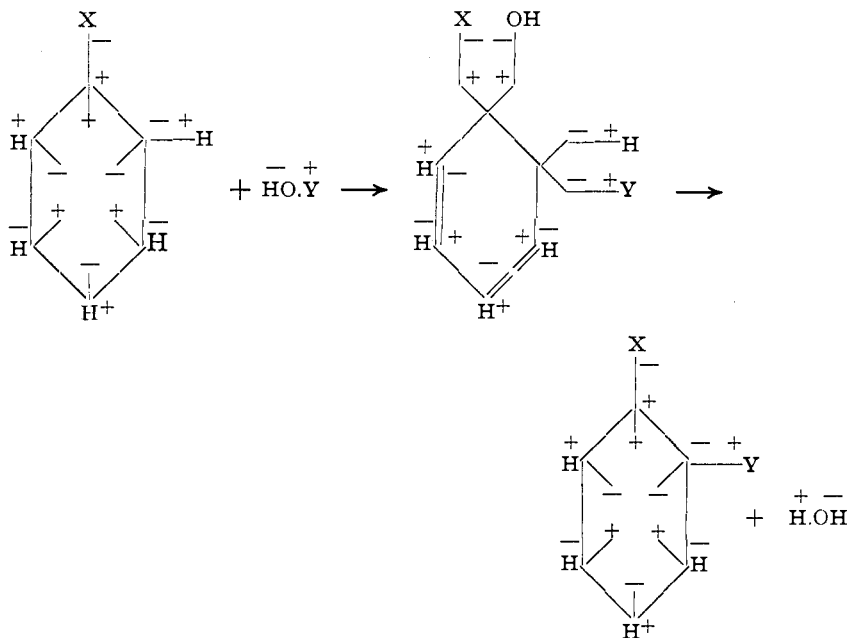

The formation of a para-disubstituted derivative also involves the electrophile in which X is negative and the entering substituent Y, positive.

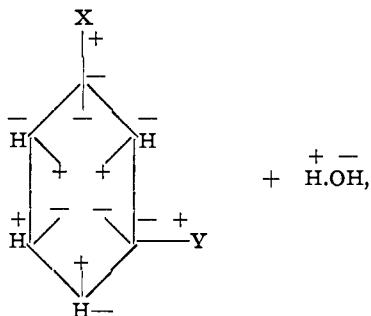

elimination of $\overset{+}{\text{H}}$ and OH^- as water and a consequent return to the centric formula of the disubstituted derivative.

The substitution of halogen ($\text{Y}_2 = \overset{+}{\text{Y}} + \overset{-}{\text{Y}}$) would correspond to the addition of $\overset{+}{\text{Y}}$ and $\overset{-}{\text{Y}}$ to the centric valences with the subsequent elimination of $\overset{+}{\text{H}}\overset{-}{\text{Y}}$ and the fixing of $\overset{+}{\text{Y}}$ in the nucleus either ortho or para to $\overset{-}{\text{X}}$, or meta to $\overset{+}{\text{X}}$. In paper II of this series (*loc. cit.*) a mechanism was given for the action of halogen carriers in effecting nucleus substitution which is also readily correlated with the above schemes. The halogen carrier forms an unstable addition compound with the radicals $\overset{+}{\text{Y}}$ and $\overset{-}{\text{Y}}$ of the halogen molecule Y_2 . This unstable addition compound either induces the direct combination of $\overset{+}{\text{Y}}$ and $\overset{-}{\text{Y}}$ with centric valences, or the dissociation products of the addition compound itself combine with the centric valences. In either event, subsequent elimination of $\overset{+}{\text{H}}\overset{-}{\text{Y}}$ and the carrier results in the nucleus substitution of $\overset{+}{\text{Y}}$.

An examination of the preceding mechanisms of substitution shows that the *polarity of the substituent X present in the nucleus and the polarities of the centric valences predetermine the types of substitution which result in the formation either of ortho- and para-derivatives, or of meta-derivatives.*

If both electromers ($\overset{+}{\text{C}_6\text{H}_5}\overset{-}{\text{X}}$ and $\overset{-}{\text{C}_6\text{H}_5}\overset{+}{\text{X}}$) interact with $\text{HO}\overset{+}{\text{Y}}$, simultaneous formation of ortho-, para-, and meta-derivatives follows as previously described and confirmed by extended experimental facts and data.

It may now prove interesting to show that the mechanism for the formation of ortho-para and meta classes of derivatives as proposed by Holleman may be correlated with the electronic formulas and substitution schemes presented in this paper.

On the basis of the Kekulé formula (the centric formula would apply equally well) Holleman supposes that the substituent X, already present in the nucleus, may either promote or retard the addition of the radicals

of the substituting reagent to the double bonds (or centric valences). If X promotes addition, the ortho and para compounds are formed, addition having taken place in position 1,2 (or 1,6) and 1,4, respectively. Conjugation is assumed to cause the addition in the para (1,4) position according to Thiele's hypothesis. On the other hand, the addition of the substituting reagent to the double bond (or centric valences) of carbon atoms 2 and 3 cannot be greatly influenced by X, because X is not in direct relation with these atoms. In other words, under the influence of X, the speed of addition to position 1,2 (or 1,6) and 1,4 is either accelerated or retarded, while the speed of addition to position 2,3 (or 5,6) is about the same as in the nonsubstituted benzene itself. Accordingly, when X accelerates the reaction, substitution takes place in positions ortho and para; when the acceleration is great, the ortho and para products will be formed exclusively, for the quantity of the meta product which could be formed simultaneously through addition to position 2,3 is then so small that it is not perceptible. When, on the other hand, the acceleration is not so great, the meta isomer may also be formed.

In the case where X retards the reaction, the addition to position 2,3 predominates and proceeds more rapidly than the addition to position 1,2 (or 1,6) and 1,4. The meta isomer then becomes the principal product.

Holleman illustrates the mechanism of these types of addition by supposing C_6H_5X to undergo nitration, in which case nitric acid adds as HO and NO_2 . The addition compounds are as follows:

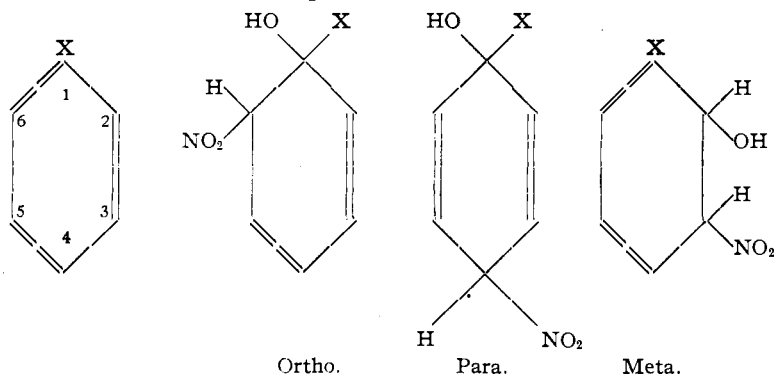

By the subsequent removal of H and OH as water, an ortho, a para or a meta compound is formed.

Now it should be noted that the above addition compounds as formulated by Holleman are identical with the electronic formulas for the addition compounds previously indicated, but with this important exception: the electronic formulas, by indicating the polarities of the hydrogen atoms, the substituents, the centric valences, and the radicals of the substituting reagent, make possible a formula-mechanism by which addition must take

place in one way rather than in some other way. On the other hand, the ordinary Kekulé and centric formulas cannot, *per se*, indicate why addition should proceed in one way rather than another. For instance, the addition of $\text{HO}\cdot\text{NO}_2$ in Holleman's scheme unites OH to carbon atom 1, and NO_2 to carbon atom 6. Now as far as the regular Kekulé or centric formula is concerned OH might just as well unite to atom 6 while NO_2 unites to atom 1. Other additions are structurally possible in positions 1,4 and 2,3. In other words, six types of addition instead of the three as indicated by Holleman are possible from the standpoint of the ordinary structural formulas. Hence, it is evident that some qualification or limitation of the types of addition must be made. This, of course, is true of any hypothesis which deals with structural formulas and proposed mechanisms of reaction, but the marked superiority of electronic formulas over ordinary structural formulas lies in the fact that the valences of the atoms and radicals may be qualified, in conformity with facts of experiments, as positive or negative, a distinction which cannot be embodied in the ordinary formulas. Therefore, a valence hypothesis which permits of such qualifications possesses greater significance in the interpretation of chemical phenomena than the ordinary valence hypothesis.

It may now be demonstrated that Holleman's formulas for the ortho, para, and meta addition compounds may be interpreted in terms of positive and negative valences. Furthermore, this interpretation logically leads to the same electronic formulas that were proposed for these addition compounds in the first part of this section (D). This necessarily follows if we admit that the electronic formulas of water and nitric acid are $\overset{+}{\text{H}}\cdot\overset{-}{\text{O}}\text{H}$ and $\overset{-}{\text{H}}\cdot\overset{+}{\text{O}}\cdot\text{NO}_2$, respectively; and, that the benzene molecule is symmetrically constituted, *i. e.*, from the electronic point of view that for every positive charge or valence there is a corresponding negative charge or valence. The correlation of Holleman's formulas with the electronic formulas is as follows:

In Holleman's ortho addition compound, the union of $\overset{+}{\text{O}}\text{H}$ with carbon atom 1 and $\overset{-}{\text{N}}\text{O}_2$ with carbon atom 2 or 6 means that the free valence of atom 1 is positive while that of atom 2 or 6 is negative. In the para addition compound, $\overset{+}{\text{N}}\text{O}_2$ unites to carbon atom 4 which, accordingly, possesses a free negative valence. In other words, the ortho and para addition compounds show that the centric valences of positions 2, 4, and 6 are negative while 1 is positive. Consequently, from the symmetry standpoint, the centric valences of positions 3 and 5 are positive just as 1 is positive.

The polarities of the hydrogen atoms and substituents of the nucleus are indicated by Holleman's assumption that the disubstituted derivative

is formed through the elimination of water, $\overset{+}{\text{H}}\overset{-}{\text{O}}\text{H}$. In Holleman's formula for the ortho addition compound, the hydrogen atom of position 2 or 6 is eliminated with the hydroxyl radical of position 1; and in the para addition compound the hydrogen atom of position 4 is likewise eliminated with hydroxyl of position 1. Since the elimination of water is the union of $\overset{+}{\text{H}}$ and $\overset{-}{\text{O}}\text{H}$, it follows that the hydrogen atoms of positions 2, 4, and 6 of the ortho and para nitrocompounds of Holleman are positive. Consequently, from the symmetry standpoint, the hydrogen atoms or substituents of position 1, 3, and 5 are negative. As a matter of fact, the ortho and para nitrocompounds, in which $\text{X} = \text{Cl}$ or Br , readily exchange X for hydroxyl on treatment with aqueous potassium hydroxide: since OH is negative, X is accordingly negative.

Having correlated Holleman's ortho and para compounds with the electronic formulas, consider, on the other hand, his formula for the meta addition compound. Here, $\overset{-}{\text{HO}}$ unites with the free valences of carbon atoms 2 or 6, while $\overset{+}{\text{NO}}_2$ combines with those of atoms 3 or 5. Hence, the free or centric valences of positions 2 and 6 are positive while those of positions 3 and 5 are negative; and from the electronic symmetry standpoint, the remaining centric valences of positions 1 and 4 must be negative and positive, respectively. Thus in the meta nitrocompound the centric valences of carbon atoms 1, 3, and 5 are negative while those of atoms 2, 4 and 6 are positive. Considering the polarities of the hydrogen atoms and substituents, $\overset{+}{\text{NO}}_2$ replaces the hydrogen atom of position 3 or 5, which is accordingly positive. From the symmetry standpoint X of position 1 should also be positive. As a matter of fact, when $\text{X} = \text{NO}_2$, as in nitrobenzene ($\overset{-}{\text{C}}_6\overset{+}{\text{H}}_5\overset{+}{\text{NO}}_2$), the entrance of a second $\overset{+}{\text{NO}}_2$ is in positions 3 or 5, meta to position 1. Furthermore, when $\text{X} = \text{Cl}$ or Br in the meta nitrocompounds, X is not directly replaceable by negative hydroxyl and is presumably positive. The atoms of positions 1, 3 and 5 being positive, those of positions 2, 4 and 6 are negative.

From the above it is evident that Holleman's formulas and mechanism of substitution may be interpreted in terms of positive and negative valences, and the electronic formulas thereby developed are correlated with the electronic formulas and principles previously presented. Therefore, the numerous cases of substitution which have been interpreted by Holleman's hypothesis are also interpreted by the electronic formulas and principles which possess the added significance of showing why certain substituents (which are negative) lead to the formation of ortho- and para-derivatives, while others (which are positive substituents) lead to the formation of meta-derivatives.

The remaining features of Holleman's substitution hypothesis to be considered from the positive and negative viewpoint relate to the velocities of the substitution reactions and their dependence upon the nature of the substituents which are present in the nucleus. Thus, when a substituent, X, accelerates the substitution reaction, substitution follows the ortho-para rule which may lead to the exclusion of any meta compound. If X has no such accelerating effect, smaller or larger quantities of the meta compound will be formed. These facts make it possible to predict the place that a third substituent C will occupy in the nucleus of a disubstituted derivative, C_6H_4AB . This place is determined by Holleman by measuring the speeds of substitution of C in C_6H_5A and in C_6H_5B , and by ascertaining the proportions in which the isomers of C_6H_4AC and C_6H_4BC are formed in each case. A comparative study from these points of view enables Holleman to determine the relative effects of different substituents upon the speeds of substitution reactions. Thus, one substituent, HO, is found to have a greater accelerating effect than another, NH_2 (represented thus, $OH > NH_2$); and a comparison of these relative effects leads to a series. For instance, the substituents which lead to the formation of ortho- and para-derivatives are arranged thus: $OH > NH_2 > \text{halogens} > CH_3$. The substituents which lead to the formation of meta-derivatives present the series: $CO_2H > CHO > SO_3H > NO_2$.

A *propos* of his hypothesis, Holleman has just recently stated¹ that the cause for the different accelerating effects of the different substituents has not yet been explained. This "cause" may be interpreted in terms of the electronic conception of positive and negative valences, since I have shown that the types of substitution are directly related to the polarities of the substituents present in the nucleus and the tendencies of these to function in one way rather than in another way. For instance, as shown in Part III, those substituents which lead chiefly to the formation of ortho- and para-derivatives are the substituents which tend to function negatively rather than positively ($\overset{-}{X} > \overset{+}{X}$), while those substituents which lead chiefly to the formation of the meta compound are the very substituents which tend to function positively rather than negatively ($\overset{+}{X} > \overset{-}{X}$). Moreover, a substituent which is naturally negative may manifest a greater tendency to function negatively than another negative substituent, thus ($\overset{-}{X} > \overset{-}{Y}$); and analogously for positive substituents there exists the relation ($\overset{+}{X} > \overset{+}{Y}$). These respective tendencies were shown in Sections A and B of Part IV to account for the preponderance of one electromer over another in the electronic tautomerism of benzene derivatives. This preponderance or increased concentration, in turn, accounted for the rela-

¹ *Recueil*, 33, 1 (1914).

tive yields of the several possible isomers. Therefore, if the greater concentration of one electromer in the equilibrium system is determined by the tendencies of its substituents to function in one way rather than in another way, and since the speed of a reaction is a factor of the concentrations of the interacting substances, it follows that the speed of a substitution reaction is dependent upon the polarities of the substituents present in the nucleus and their respective tendencies to function in certain ways. From this point of view it follows that Holleman's series $(\text{OH} > \text{NH}_2 > \text{halogens} > \text{CH}_3)$ may be represented thus: $\overline{\text{OH}} > \overline{\text{NH}_2} > \overline{\text{halogens}} > \overline{\text{CH}_3}$. The other series is as follows: $\overset{+}{\text{CO}_2\text{H}} > \overset{+}{\text{CHO}} > \overset{+}{\text{SO}_3\text{H}} > \overset{+}{\text{NO}_2}$.

If the tendency for a substituent to function in one way rather than in another way be defined as the "polar stability of the substituent," it follows that the velocities of substitution reactions in the benzene nucleus are functions of the polar stabilities of the substituents of the nucleus. In other words, the polar stabilities of the substituents determine the concentrations of the electromers, which concentrations are the principle factors in determining the velocities of the substitution reactions.

A summary of Part IV may be omitted since the several topics discussed have been presented in separate sections with contents indicated. This paper, however, should be concluded with the following general statements: The conception of the electronic tautomerism of the derivatives of benzene furnishes an explanation of (1) the types of substitution and the simultaneous formation of ortho-, para-, and meta-substituted derivatives; (2) it renders possible the prediction of the relative yields of the isomers which are dependent upon the preponderance or increased concentration of one electromer over the other; (3) the concentrations of the electromers are predetermined by the "polar stabilities" of the substituents in the nucleus; (4) the velocities of substitution reactions are functions of the polar stabilities of the substituents. Accordingly all facts that are explained in terms of the velocities of reactions may be interpreted in terms of the polar stabilities of the substituents. This phase of substitution in the benzene nucleus will be considered in detail in a subsequent paper.

V. A REPLY TO A. F. HOLLEMAN.

In a recent paper¹ entitled "Substitution in the Benzene Nucleus," Dr. A. F. Holleman has taken exceptions to the electronic formula for benzene and the general rule for substitution; and has offered a number of objections. In view of the principles developed in the preceding

¹ THIS JOURNAL, 36, 2495 (1914).

Part III, and the many applications of the conception of the electronic tautomerism of benzene derivatives presented in Part IV, it may now be shown that the chief objections offered by Holleman actually confirm and substantiate the electronic formulas for benzene and the rule for substitution. Other incidental objections will be considered in course of the reply.

In Holleman's paper the several objections are presented in separate paragraphs numbered 1-6. The present reply will consider the contents of each of these paragraphs in the same order.

(1) Holleman's first objection is directed against the assumption that monochlorobenzene may be an equilibrium mixture of two tautomeric electromers, $\overset{+}{\text{C}_6\text{H}_5}\overset{-}{\text{Cl}}$ and $\overset{-}{\text{C}_6\text{H}_5}\overset{+}{\text{Cl}}$. Granting such to be the case, Holleman maintains that if $\overset{-}{\text{C}_6\text{H}_5}\overset{+}{\text{Cl}}$ is stable, $\overset{+}{\text{C}_6\text{H}_5}\overset{-}{\text{Cl}}$ would be unstable. This I also admit provided we qualify this stability or instability in terms of the tendency for chlorine to function negatively rather than positively, *i. e.*, $\overset{-}{\text{Cl}} > \overset{+}{\text{Cl}}$, which tendency explains the preponderance or greater concentration of the one electromer over the other and the consequent increase in its reaction velocity. But to Holleman's statement that

("in *o*- $\text{C}_6\text{H}_4\text{Cl}_2$ and *p*- $\text{C}_6\text{H}_4\text{Cl}_2$, where one atom is negative and the other positive, we have perfectly stable compounds,")

the reply may be made that the existence of a perfectly stable compound is questionable. Stability is only a relative term and a given compound, so to speak, may be perfectly stable under one set of conditions, but unstable under others. Furthermore, a given atom or radical may be reactive in one compound but nonreactive in another: for example, the replacement of chlorine in *o*- and *p*-chloronitrobenzene by OH on interaction with K.OH; and the nonreplacement of chlorine in *m*-chloronitrobenzene under the same conditions. Again, in one and the same compound such as *o*- and *p*-dichlorobenzene (compounds which Holleman regards as perfectly stable) there exist differences in the reactivities of their chlorine atoms, depending upon one being positive while the other is negative. This is evidenced by the fact demonstrated by de Mooy in Holleman's laboratory that each of these compounds exchanges one chlorine for OCH₃ on interaction with sodium methylate. This difference in the reactivities of the chlorine atoms is illustrated by the following electronic equation:

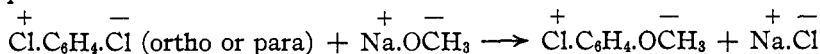

In this connection it should be noted that if halogen (X) is introduced into the benzene nucleus (either through interaction with $\overset{-}{\text{HO}}.\overset{+}{\text{X}}$ or through

the action of a halogen carrier such as SbX_3) the resultant electromer $\overset{-}{\text{C}_6\text{H}_5}\overset{+}{\text{X}}$ would revert chiefly to the tautomer $\overset{+}{\text{C}_6\text{H}_5}\overset{-}{\text{X}}$, because of the tendency $\overset{-}{\text{X}} > \overset{+}{\text{X}}$. This tendency for $\overset{-}{\text{X}}$ to function negatively rather than positively is a distinctive property and should not be confused with the replaceability of $\overset{-}{\text{X}}$ by OH or by OCH_3 .

Again, Holleman maintains that if chlorobenzene is a mixture of $\overset{+}{\text{C}_6\text{H}_5}\overset{-}{\text{Cl}}$ and $\overset{-}{\text{C}_6\text{H}_5}\overset{+}{\text{Cl}}$, the nitration of such a mixture ought to yield *o*- and *p*-chloronitrobenzenes (derived from $\overset{+}{\text{C}_6\text{H}_5}\overset{-}{\text{Cl}}$) and *m*-chloronitrobenzene (derived from $\overset{-}{\text{C}_6\text{H}_5}\overset{+}{\text{Cl}}$), when, in reality, only the ortho- and para-disubstituted compounds are formed. In reply, recall the facts presented in Part IV, Sections A and B, showing that $\overset{-}{\text{Cl}} > \overset{+}{\text{Cl}}$, which tendency accounts for the preponderance or increased concentration of $\overset{+}{\text{C}_6\text{H}_5}\overset{-}{\text{Cl}}$ over $\overset{-}{\text{C}_6\text{H}_5}\overset{+}{\text{Cl}}$. Accordingly, the speed of interaction of the former electromer with nitric acid would exceed that of the latter electromer. Now in terms of Holleman's own hypothesis on the speeds of reaction and type of substitution, if the speed of substitution is sufficiently great, *o*- and *p*-chloronitrobenzenes would be formed to the exclusion of the meta compound. Therefore, Holleman's experimental demonstration that chlorobenzene yields only *o*- and *p*-chloronitrobenzenes may be accepted as proof that in the tautomeric equilibrium, $\overset{+}{\text{C}_6\text{H}_5}\overset{-}{\text{Cl}} \rightleftharpoons \overset{-}{\text{C}_6\text{H}_5}\overset{+}{\text{Cl}}$, the former electromer interacts exclusively with $\text{HO}\cdot\text{NO}_2$. In contending that both electromers must interact with nitric acid, Holleman has disregarded the general principle that in a tautomeric equilibrium mixture, either one or the other, or both tautomers may interact with a given reagent. See Part IV, Section B, third paragraph, for further description and electronic equations.

(2) In his second paragraph Holleman states that:

"Fry maintains that the iodine is positive in iodobenzene, since it is formed from sodium benzoate and iodine chloride, the latter having the formula $\text{Cl}-\overset{-}{\text{I}}$. But iodobenzene also yields para and ortho compounds on nitration, just as the other halogen-benzenes, though in these the halogen is admitted to have a negative charge."

In reply, Holleman has misstated me with reference to iodobenzene since the reaction in question is that of $\text{Cl}-\overset{-}{\text{I}}$ upon silver benzoate (not sodium benzoate)¹ showing that the iodine atom in iodobenzoic acid (and not iodobenzene) is positive. The nitration of iodobenzene from the electronic point of view is identical with the nitration of the other

¹ As described in THIS JOURNAL, 36, 254-255 (1914).

halogen-benzenes, $C_6H_5.X \rightleftharpoons C_6H_5.X$, in which the former electromer may predominate to the exclusion, of the latter, whereupon only ortho- and para-derivatives are formed.

Further, Holleman states:

"It is somewhat striking that Fry admits on p. 252, *Loc. cit.*, that chlorobenzene has the formula $C_6H_5.Cl$, whereas he declares on p. 264, that it has been impossible so far to prove directly, whether the chlorine atom in monochlorobenzene is positive or negative."

In reply, the first part of the above statement is a misinterpretation since my original statement was as follows (*loc. cit.*, pp. 251-2): "According to the principles previously developed from the Crum Brown and Gibson Rule, the electronic formula of chlorobenzene is $C_6H_5.Cl$ while that of nitrobenzene is $C_6H_5.NO_2$." In other words, chlorobenzene is a derivative of $H.Cl$ from the standpoint of the Brown and Gibson Rule, and, accordingly, is regarded as $C_6H_5.Cl$. In the further development of this rule and the electronic tautomerism of benzene derivatives, chlorobenzene is $C_6H_5.Cl \rightleftharpoons C_6H_5.Cl$. My statement (*loc. cit.*, p. 264): "it has been impossible so far to prove directly whether the chlorine atom in monochlorobenzene is positive or negative"—was made with reference to the possibility of hydrolyzing chlorobenzene so as to obtain: (1) from $C_6H_5.Cl$, the products $C_6H_5.OH$ and $H.Cl$; and (2) from $C_6H_5.Cl$, the products $C_6H_5.H$ and $HO.Cl$. This has not been possible with chlorobenzene but similar hydrolyses have been accomplished with benzene sulfonic acid (*loc. cit.*, p. 265).

The objections presented in paragraph (2) are thus shown to involve a misstatement and a misinterpretation neither of which invalidates the electronic formula for benzene or the rule for substitution.

(3) In his third paragraph Holleman states that:

"According to Fry, 'the radical SO_3H in phenylsulfonic acid may function either positively or negatively.' He deduces this from the fact that this acid yields benzene on heating with water or acids, but phenol on melting with alkali. But since in *o*- and *p*-phenylene disulfonic acid one SO_3H should be positive when the other is negative, these acids should yield phenol exclusively on melting with alkali. In reality they yield pyrocatechol and hydroquinol."

In reply this objection is apparently justified but it is invalidated by Holleman's failure to take into account the fact that whether the SO_3H radical be positive or negative, *in alkaline solution it functions negatively*. For instance, since phenylsulfonic acid is a mixture of tautomeric electromers ($C_6H_5.SO_3H \rightleftharpoons C_6H_5.SO_3H$), the former would revert to the latter *in acid solution*, but *in alkaline solution* the latter reverts to the

former, *i. e.*, $\overset{+}{\text{SO}_3\text{H}}$ becomes $\overset{-}{\text{SO}_3\text{H}}$ and is replaced by $\overset{-}{\text{OH}}$ on hydrolysis. Applying this principle to *o*- or to *p*-phenylene disulfonic acid, each containing $\overset{+}{(\text{SO}_3\text{H})}$ and $\overset{-}{(\text{SO}_3\text{H})}$, fusion with alkali would cause both radicals to function negatively with consequent replacement by negative hydroxyl yielding pyrocatechol and hydroquinol:

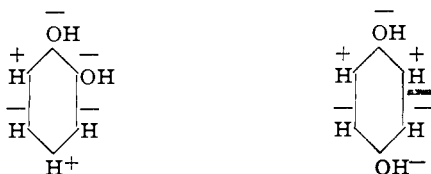

At once it will be contended that these electronic formulas are exceptional since the general rule has consistently maintained that substituents ortho and para to each other are of opposite polarity. Granting the above formulas to be exceptions we are presented with evidence that substantiates a fundamental principle, namely, that if the polarities of the hydrogen atoms or substituents of the nucleus do not conform to the general electronic formula for benzene, then the stability of the benzene nucleus is radically affected. Now this ensuing instability actually manifests itself in the fact that *o*-, *m*-, and *p*-bromobenzenesulfonic acids, and *m*- and *p*-phenylene disulfonic acids, all yield one and the same dihydric phenol—namely, the *meta* compound, resorcinol, on fusion with potassium hydroxide. Perkin and Kipping,¹ commenting upon these anomalies state that the ortho and para dihydric compounds which are first produced from the corresponding bromosulfonic acids (or from the corresponding phenylene disulfonic acids) are unstable and are converted into the more stable *meta*-derivative by intramolecular change. Now the electronic hypothesis readily furnishes an interpretation of this instability as due to the disarrangement of the electronic symmetry of the electrical charges when radicals ortho or para to each other are of the same sign. For instance, all of the changes involved in the conversion of *p*-phenylenedisulfonic acid to resorcin are illustrated in the following electronic formulas and scheme:

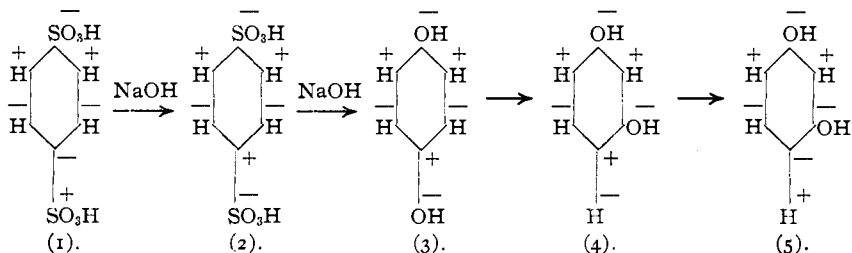

¹ "Organic Chemistry," pp. 436-7 (1911).

Formula 1 is the natural symmetrical *p*-disulfonic acid. In alkaline medium $\overset{+}{\text{SO}}_3\text{H}$ becomes $\overset{-}{\text{SO}}_3\text{H}$, *i. e.*, the negative valence of C-atom 4 is converted to a positive valence (by the loss of two electrons which render $\overset{-}{\text{SO}}_3\text{H}$ negative) and the resulting Formula 2 is not symmetrical. Hydrolysis yields the nonsymmetrical and unstable dihydric phenol of Formula 3 which undergoes intramolecular rearrangement. This rearrangement may be attributed to two tendencies: first, $\text{OH} > \overset{-}{\text{H}}$, and second, $\overset{+}{\text{H}} > \overset{-}{\text{H}}$. The first is fulfilled when OH occupies position 3 meta to OH in position 1. The second leads to the change in the polarity of carbon valence 4, $\overset{-}{\text{H}}$ becoming $\overset{+}{\text{H}}$ (as in Formula 5) which completes the transition to the symmetrical and stable resorcin.

(4) In the fourth paragraph, Holleman indicates the electronic formulas of *p*-chlorotoluene and *p*-chlorobromobenzene and maintains that if Fry's rule were correct we should obtain, on nitration, only one nitrochlorotoluene and only one nitrochlorobromobenzene; when, as a matter of fact, Wibaut and Heineken proved that in both cases, considerable quantities of two isomers are obtained. In reply, this objection is invalidated because Holleman failed to take into account the two electromers (electronic tautomers) of each of these para compounds. A detailed explanation of the introduction of a third substituent Z (= NO₂) into a para-disubstituted derivative, C₆H₄XY (X = Cl; Y = CH₃ or Br) is given in detail in Part IV, Section B, Scheme 2, which shows that the researches of Wibaut (as quoted by Holleman) actually confirm the electronic tautomerism of the derivatives and rule for substitution.

Again, Holleman states that the nitration of *o*-chlorotoluene yields, as shown by Wibaut, all four possible isomers of nitrochlorotoluene, while Fry's rule predicts the formation of only two isomers. In reply, Holleman again fails to consider the part played by both tautomeric electromers of *o*-chlorotoluene on nitration. In Part IV, Section B, Scheme 1, I have shown that the introduction of a third substituent into an ortho-disubstituted derivative yields *four* possible isomers. The work of Wibaut, discussed in this section, affords a striking confirmation of the electronic tautomerism of *o*-chlorotoluene and the electronic scheme for its nitration.

The fact that Holleman obtains only two isomers when *o*-chlorobromobenzene is nitrated accords with the fact that only one of the electromers enters into reaction with nitric acid. This is perfectly analogous to the nitration of monochlorobenzene in which only one electromer enters into reaction with consequent formation of only two isomers.

In concluding this part of the reply, each of the objections cited by Holleman in the fourth paragraph of his criticism, accords with and, therefore,

substantiates the electronic formulas, the schemes of electronic tautomerism and the rule for substitution as resented in Part IV, Section B.

(5) In his fifth paragraph Holleman states:

"Fry's explanation of the fact that the chlorination of nitrobenzene yields *m*-nitrochlorobenzene, can neither be accepted. He supposes that HO.Cl is the chlorinating agent 'since absolutely anhydrous chlorine does not react with anhydrous reagents.' However, this introduction of chlorine is only possible, when a large quantity of SbCl₃ is added (¹/₅ of the weight of the nitrobenzene). All traces of water must be taken away by it."

In reply, it cannot be asserted absolutely that all traces of water are removed by SbCl₃ because its interaction with water is a decidedly reversible reaction which may be represented electronically as follows:

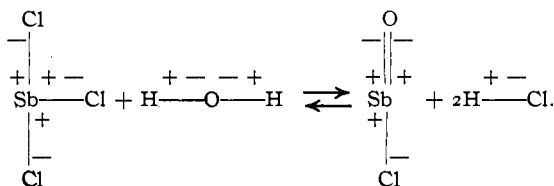

Holleman then continues:

"The only plausible explanation is, that SbCl₅ is formed which transports chlorine to the nitrobenzene, As there can be little doubt that SbCl₅ is SbCl₅ (always according to the views of Fry), chlorine ought to replace an *o*- or *p*-H-atom in C₆H₅NO₂, when NO₂ in it is positive."

In reply to this statement, I am perfectly willing to admit that SbCl₃ may act as a halogen carrier through the intermediate formation of SbCl₅, but I have never claimed (as attributed to me by Holleman) that SbCl₅ is SbCl₅, which as an electronic formula is meaningless. The electronic formula for SbCl₃ is given in the hydrolysis equation above, and its combination with chlorine to act as a halogen carrier is as follows:

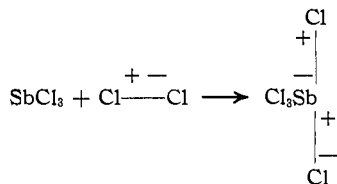

Now, in Part II of this series, THIS JOURNAL, 36, on page 1042, I have given an explanation and scheme for the action of halogen carriers in effecting the nucleus substitution of *positive halogen*. The action of SbCl₅ as a halogen carrier conforms perfectly with this explanation and scheme for the nucleus substitution of positive chlorine which must assume a position meta to the positive nitro radical in nitrobenzene. See the complete electronic scheme for the formation of a meta-disubstituted de-

rivative in Part IV, Section D, which also shows that positive chlorine must replace a meta-hydrogen atom in $\overset{-}{\text{C}_6\text{H}_5}\overset{+}{\text{NO}_2}$ and not an ortho or para hydrogen atom as incorrectly attributed to my hypothesis by Holleman.

(6) In the sixth paragraph, Holleman, admitting Fry's explanation of the replacement of negative chlorine in *o*- and *p*-chloronitrobenzenes by negative hydroxyl, and the nonreplacement of positive chlorine in *m*-chloronitrobenzene, states:

"One chlorine should also be replaceable by OCH_3 in *o*- and *p*-dichlorobenzene, $\overset{-}{\text{Cl}}\overset{+}{\text{C}_6\text{H}_4}\overset{-}{\text{Cl}}$, but not in *m*-dichlorobenzene, $\overset{-}{\text{Cl}}\overset{+}{\text{C}_6\text{H}_4}\overset{-}{\text{Cl}}$ (or $\overset{-}{\text{Cl}}\overset{+}{\text{C}_6\text{H}_4}\overset{+}{\text{Cl}}$). However, deMooy (work not yet published) has proved in my laboratory, that the latter also reacts with sodium methylate, and that the velocity of this reaction is even greater than for the para and ortho isomers, one Cl-atom being replaced in all three compounds."

In reply, this is just what the electronic hypothesis would naturally predict, for if *m*-dichlorobenzene is a mixture of the electronic tautomers, $\overset{-}{\text{Cl}}\overset{-}{\text{C}_6\text{H}_5}\overset{-}{\text{Cl}} \rightleftharpoons \overset{+}{\text{Cl}}\overset{+}{\text{C}_6\text{H}_5}\overset{+}{\text{Cl}}$, then the former electromer in which chlorine is negative would naturally predominate (since $\overset{-}{\text{Cl}} > \overset{+}{\text{Cl}}$) and lend itself to interaction with $\overset{+}{\text{Na}}\overset{-}{\text{OCH}_3}$ according to the equation:

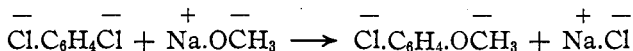

Furthermore, I have shown in Part IV, Section B, under Scheme 3, that in a meta-disubstituted derivative, if both substituents tend to function negatively rather than positively (as is the case in *m*-dichlorobenzene) then that electromer will tend to predominate to the exclusion of the other electromer. Hence, the predominance or increased concentration of the electromer $\overset{-}{\text{Cl}}\overset{-}{\text{C}_6\text{H}_4}\overset{-}{\text{Cl}}$ explains its greater speed of interaction with $\overset{+}{\text{Na}}\overset{-}{\text{OCH}_3}$. An analogy is afforded in the greater speed of interaction between $\overset{+}{\text{C}_6\text{H}_5}\overset{-}{\text{Cl}}$ and nitric acid than between $\overset{-}{\text{C}_6\text{H}_5}\overset{+}{\text{Cl}}$ and nitric acid, previously considered. Accordingly the velocity of reaction between $\overset{-}{\text{Cl}}\overset{-}{\text{C}_6\text{H}_4}\overset{-}{\text{Cl}}$ and sodium methylate would be greater than the velocity of reaction between $\overset{+}{\text{Cl}}\overset{+}{\text{C}_6\text{H}_4}\overset{-}{\text{Cl}}$ (*o* or *p*) and sodium methylate.

Thus the experimental facts presented by Holleman in his sixth paragraph of objections are found to be in harmony with the electronic principles previously developed and applied.

In his concluding paragraph, Holleman states:

"I wish, finally, to call attention to two further points. In the first place, it would probably be very difficult to designate what charge a given substituent has. In most cases it might as well be positive as negative. This naturally leads to a great uncertainty in the explanation of reactions."

In reply, it may be admitted that difficulties are sometimes encountered in determining the charge of a given substituent, but this is not always so. For instance, W. A. Noyes, Stieglitz, L. W. Jones, Falk and Nelson, Bray and Branch, and others, have made extended and highly significant applications¹ of the electronic conception of positive and negative valences, and have demonstrated that the reactions of hydrolysis may be employed frequently to determine the polarity or charge of certain radicals. Furthermore, in Part III of this series, in the further analysis of the Brown and Gibson rule, I have shown that those various substituents which lead to the formation of ortho- and para-derivatives do so by virtue of their *negative polarity*, while those various substituents which lead to the formation of meta-derivatives do so by virtue of their *positive polarity*. In other words, the *ortho-para* and *meta* types of substitution in the benzene nucleus afford a key to the determinations of the polarities of numerous substituents.

While it is true that a given substituent may function either positively or negatively, I have shown that said substituent possesses a definite and a pronounced tendency to function in one way rather than in another way. This fact has been of great importance to the conception of electronic tautomerism and the explanation of (1) the simultaneous formation of ortho-, meta- and para-derivatives, (2) the velocities of substitution reactions, and (3) the relative yields of the possible isomers. Further confirmations of these principles are reserved for subsequent papers. Hence, we may conclude that the determination of the polarity of a substituent is neither so difficult nor as uncertain as some might be inclined to judge. Further developments of the electronic conception of positive and negative valences are certain to throw more light upon this phase of the subject.

Finally, Holleman states:

"In the second place, I might direct attention on the consequences of the hypothesis in the case of open chains. For these it leads to the formula $\overset{+}{\text{C}}-\overset{-}{\text{C}}-\overset{+}{\text{C}}-\overset{-}{\text{C}}$, for the linking of the C-atoms comes about by C-atom 1 giving off an electron to C-atom 2, this sending off an electron in its turn to C-atom 3, and so on. This must cause the C-atoms at both ends of the open chain to have opposite signs. This would involve the consequence that the Br-atoms, *e. g.*, in a polymethylene dibromide, ought to show a different behavior, which is also in contradiction with the experimental facts."

In reply, this final objection of Holleman is itself subject to criticism because his assumption relative to the electronic nature of the open carbon chain is arbitrarily limited to only one type of linking. It is equally possible to have carbon chains of several types. For example, the following type would accommodate halogen atoms of the same polarity at each

¹ See references to the articles of these authors throughout the present series of papers.

end of the chain: $\overset{+}{\text{C}}-\overset{+}{\text{C}}-\overset{-}{\text{C}}-\overset{-}{\text{C}}-\overset{+}{\text{C}}-\overset{+}{\text{C}}-\overset{-}{\text{C}}-\overset{-}{\text{C}}-\overset{+}{\text{C}}-\overset{+}{\text{C}}$. I shall also show in a later paper that halogen atoms at the ends of an open carbon chain are of opposite polarity just as are the halogen atoms on carbon atoms 1 and 4 of the benzene nucleus in *p*-dichlorobenzene.

In conclusion, it may be said that criticisms of a hypothesis should be and are welcomed because they serve to develop either its merits or demerits. The electronic hypothesis of positive and negative valences, while comparatively new, is a rapidly growing conception as is evidenced by the articles of the authors noted above who have presented many significant applications, interpretations, and deductions. The present series of papers relating chiefly to the constitution of benzene and its derivatives, has interpreted many hitherto unexplained phenomena. The fact that electronic formulas, in many instances, have proven to be of *greater significance than the ordinary structural formulas lends support* to the idea that the electronic conception of positive and negative valences may become not only a significant but possibly a necessary adjunct to the structure theory. This however, must depend upon the extent of its applications and experimental verifications, and upon the part that is played by just criticisms in bringing to light the relative merits and demerits of its applications.

CINCINNATI, O.

[CONTRIBUTION FROM THE CHEMICAL LABORATORY OF SYRACUSE UNIVERSITY.]

A METHOD FOR THE SEPARATION AND IDENTIFICATION OF CERTAIN HOMOLOGOUS α -DIKETONES.

By J. M. JOHLIN.

Received January 25, 1915.

The author has made the observation that diacetyl occurs in considerable quantities in pyroligneous acid, and generally in smaller amounts in the distillate resulting from the destructive distillation of carbohydrates, such as pure cellulose, cane sugar, glucose, and lactose.

The fact that nickel readily precipitates as the salt of dimethylglyoxime was adapted for the precipitation of diacetyl with nickel chloride and hydroxylamine-hydrochloride. Repeated preliminary tests with synthetically prepared diacetyl showed that one part of diacetyl in one hundred thousand parts of water still gives a decided precipitate of the nickel salt of dimethylglyoxime when a few drops each of solutions of nickel chloride, hydroxylamine-hydrochloride and ammonium hydroxide are added. Although diacetyl itself is very volatile it is evident that, after adding the reagent necessary for its precipitation, concentration to any necessary extent can be effected without further loss.

Dimethylglyoxime, which can be prepared in a very pure state and accurately weighed, was found by repeated determinations to be quanti-